

# PASSENGER BACKREST PAD KIT



P/N 2879666-XXX; 2883728; 2884620-XXX; 2884727-XXX

## BEFORE YOU BEGIN

Read these instructions and check to be sure all parts and tools are accounted for. Please retain these installation instructions for future reference and parts ordering information.

## APPLICATION

Verify accessory fitment at [www.indianmotorcycle.com](http://www.indianmotorcycle.com).

## REQUIRED SOLD SEPARATELY

Only parts for installation of the Indian Motorcycle® Passenger Backrest Pad Kit are included. For complete installation, one of the following additional kits is required (sold separately):

PAD KIT	REQUIRED BACKREST KIT
2884620-XXX 2884727-XXX	2884619-XXX
2879666-XXX 2883728-XXX	2880669-XXX 2880670-XXX 2884186-XXX 2880832-XXX 2880833-XXX

### NOTICE

XXX = Indian Motorcycle® color code (For example: 266 = Black)

## KIT CONTENTS

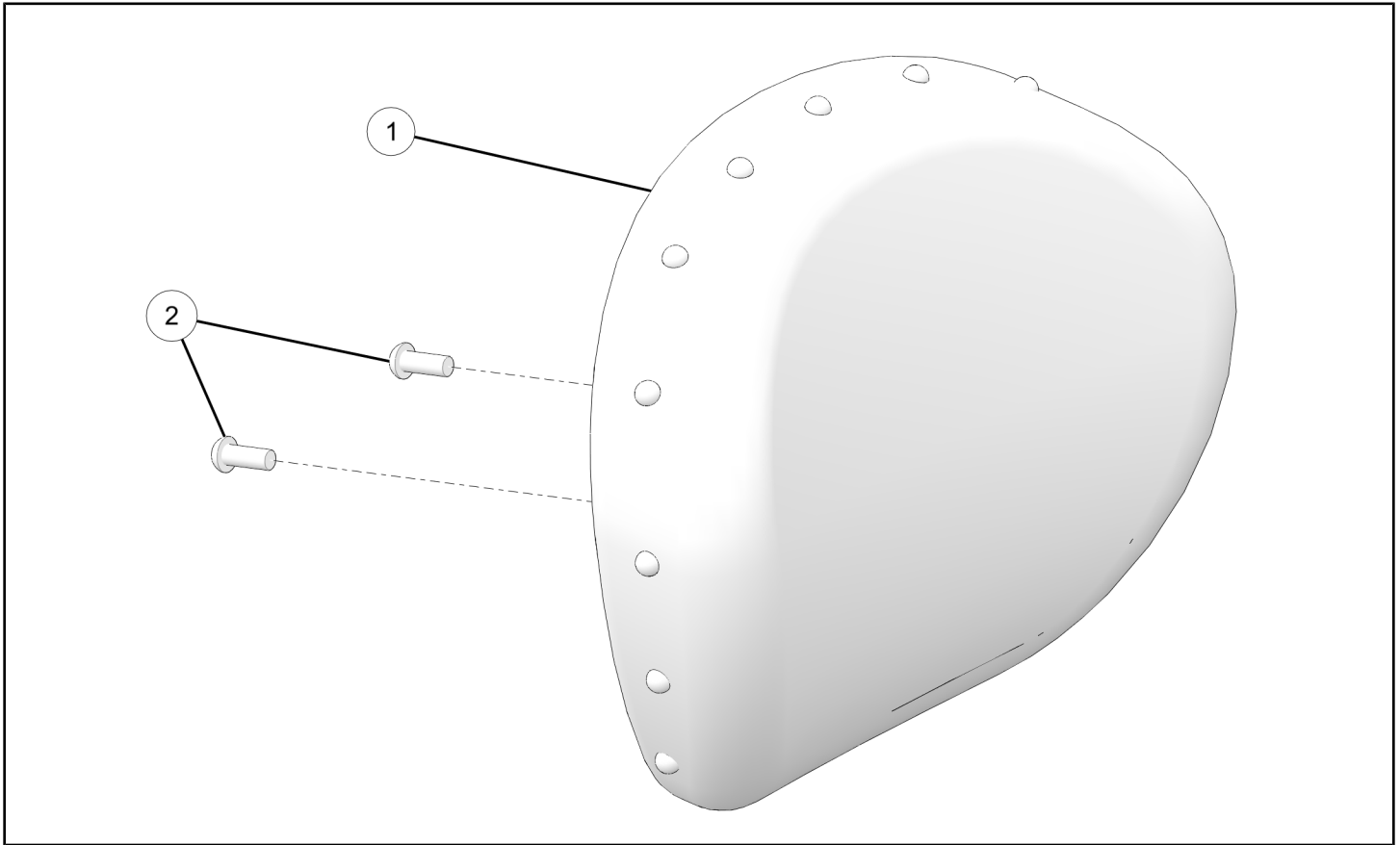

### NOTICE

XXX = Indian Motorcycle® color code (For example: 266 = Black)

REF	QTY	PART DESCRIPTION	P/N AVAILABLE SEPARATELY
1	1	Passenger Back Rest Pad	n/a
2	2	Screw, Button Head, M8 X 20 (2879666-XXX Only) Screw, Button Head, M8 X 16 (2883728-XXX Only) (Assorted Colors) Screw, Button Head, M6 X 16 (2884620-XXX and 2884727-XXX Only) (Assorted Colors)	7518305 n/a n/a

## TOOLS REQUIRED

- Safety Glasses
- Socket Set, Hex Bit, Metric
- Torque Wrench

## IMPORTANT

Your Indian Motorcycle® Passenger Backrest Pad Kit is exclusively designed for your vehicle. Please read the installation instructions thoroughly before beginning. Installation is easier if the vehicle is clean and free of debris. For your safety, and to ensure a satisfactory installation, perform all installation steps correctly in the sequence shown.

# INSTALLATION INSTRUCTIONS

## VEHICLE PREPARATION

### GENERAL

1. Turn key or ignition switch to **OFF** position and remove key. If equipped with keyless fob, remove fob from proximity of vehicle.
2. Park motorcycle on a flat surface, fully extend kickstand, and make sure vehicle is stable prior to installation.

## ACCESSORY INSTALLATION

1. Align pad ① on backrest as shown and install two screws ②. Match screw color to mount color (if applicable). Torque screws to proper specification.

### TORQUE

2879666-XXX Pad Screw ②:  
**12 ft-lbs (16 N·m)**

### TORQUE

2883728-XXX Pad Screw ②:  
**18 ft-lbs (24 N·m)**

### TORQUE

2884620-XXX and 2884727-XXX Pad Screw ②:  
**36 in-lbs (4 N·m)**

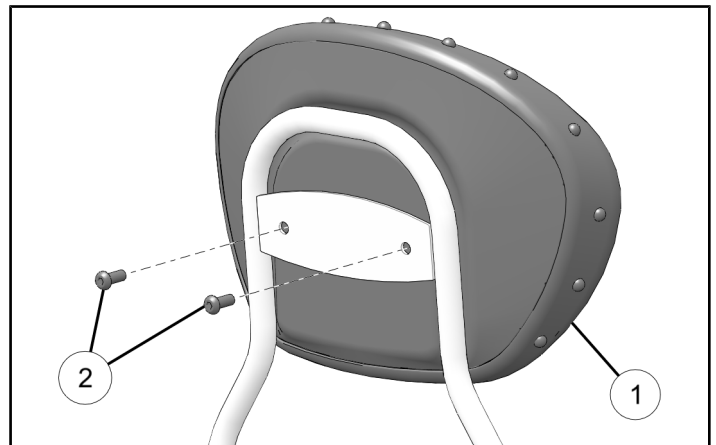

2. Clean pad with warm water, mild soap, and soft cloth. Allow pad to air dry.

### NOTICE

See owner's manual for seat and pad care instructions.

## INSTRUCTION FEEDBACK FORM

A feedback form has been created for the installer to provide any comments, questions or concerns about the installation instructions. The form is viewable on mobile devices by scanning the QR code or by clicking [HERE](#) if viewing on a PC.

